

Effects of Shock and Vibration on Product Quality during Last-Mile Transportation of Ebola Vaccine under Refrigerated Conditions¹

Linda Bus-Jacobs, Rute Lau, Marjolein Soethoudt, Lisa Gebbia, Edwin Janssens, Tjeerd Hermans

Analyzing vaccine stability under different storage and transportation conditions is critical to ensure that effectiveness and safety are not affected by distribution. In a simulation of the last mile in the supply chain, we found that shock and vibration had no effect on Ad26.ZEBOV/MVA-BN-Filo Ebola vaccine regimen quality under refrigerated conditions.

Ebola vaccine development has been accelerated in response to large outbreaks in West and Central Africa; those outbreaks have caused >32,000 cases and >13,500 deaths (1). One vaccine emerging from this effort is the heterologous Ad26.ZEBOV/MVA-BN-Filo regimen (Johnson & Johnson, <https://www.jnj.com>). Ad26.ZEBOV, an adenovirus serotype 26–vectored monovalent, recombinant, replication-incompetent vaccine, encodes the full-length Ebola virus Mayinga glycoprotein. MVA-BN-Filo, a recombinant, nonreplicating, modified vaccinia Ankara–vectored multivalent vaccine, encodes the glycoprotein of Ebola virus (Mayinga), Sudan virus (Gulu), and Marburg virus (Musoke) and the nucleoprotein of Tai Forest virus. Ad26.ZEBOV/MVA-BN-Filo received marketing authorization under exceptional circumstances for prophylactic use in persons ≥ 1 year of age in the European Union (2,3) and is on the World Health Organization’s list of prequalified vaccines (4). This vaccine regimen has been shown to be safe and immunogenic in children and adults (5–9).

Recommended long-term storage and shipping conditions are -85°C to -55°C for the Ad26.ZEBOV

component (2) and 25°C to -15°C for the MVA-BN-Filo component (3). However, infrastructure challenges may affect implementation of recommended distribution conditions, particularly in remote regions. Refrigerated (2° – 8°C) liquid transport may more easily support extended vaccine distribution to rural locations than frozen conditions. Ad26.ZEBOV/MVA-BN-Filo can maintain stability at 2° – 8°C (10). An important consideration in transporting liquid vaccines to rural areas is agitation, which can contribute to vaccine degradation and loss of potency (11). For our study, we subjected Ad26.ZEBOV/MVA-BN-Filo to simulated rough-road transport at 2° – 8°C , conditions that are representative of the final leg or last mile in the supply chain in rural areas, to assess the effect of shock and vibration on vaccine quality.

The Study

Packaging configurations (material used and shipping and storing conditions) were representative of supplies available in Africa during large vaccination campaigns (Figure; Appendix Table 1, <https://wwwnc.cdc.gov/EID/article/30/3/23-1060-App1.pdf>). We conducted simulated distribution testing in 2 sequential steps at 2° – 8°C to approximate last-mile transport in rural areas that included a shock test followed by a vibration test. The test simulated unpaved roads typical of rural areas, representing long-distance (100-km) travel that could occur between the distribution center and vaccination site, by using a rough-road transport simulation profile.

We dropped vials 9 times in various orientations from heights of 30.5–91.4 cm, depending on the weight of the shipping container (Appendix Table 2,

Author affiliations: Janssen Vaccines and Prevention B.V., Leiden, the Netherlands (L. Bus-Jacobs, R. Lau, M. Soethoudt, E. Janssens, T. Hermans); Janssen Research and Development LLC, Spring House, Pennsylvania, USA (L. Gebbia)

DOI: <https://doi.org/10.3201/eid3004.231060>

¹Preliminary results from this study were presented at the Conference on Public Health in Africa; December 13–15, 2022; Kigali, Rwanda.

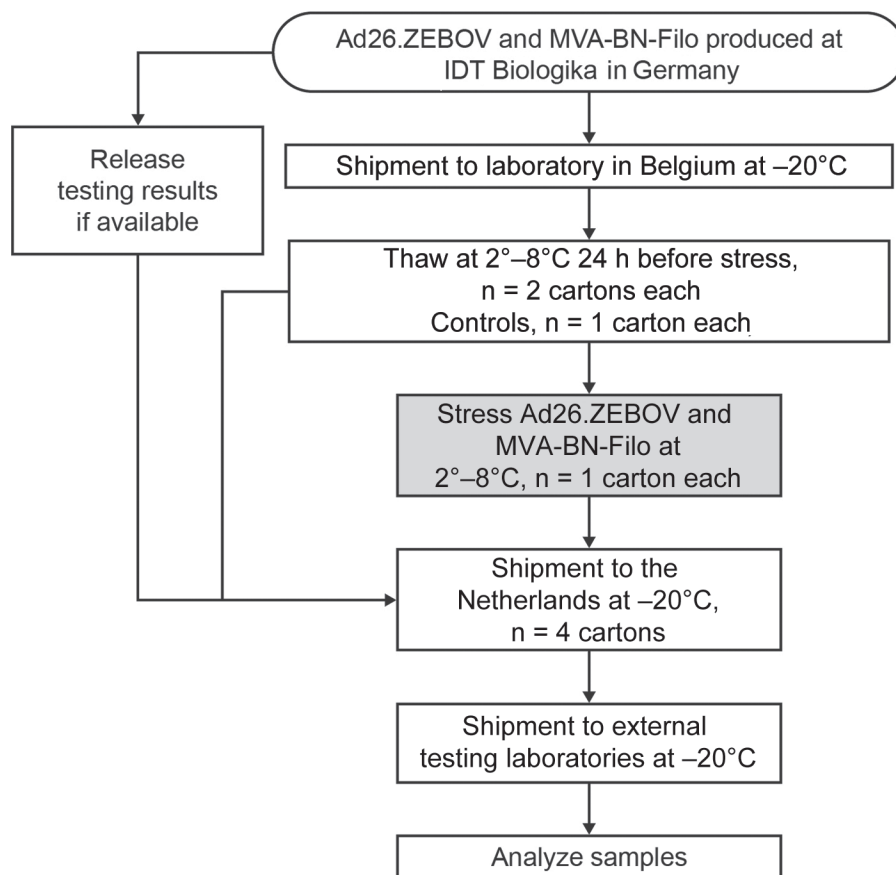

Figure. Study design to assess effects of shock and vibration on last-mile transportation of Ad26.ZEBOV/MVA-BN-Filo regimen Ebola vaccine regimen under refrigerated conditions. Ad26.ZEBOV/MVA-BN-Filo were produced and stored at -85°C to -55°C . Four paperboard cartons, each with 2 thermoformed trays containing 10 vials, were shipped to the simulation test laboratory at -20°C . The vials were thawed at $2^{\circ}\text{--}8^{\circ}\text{C}$ 24 h before testing and packed into insulated shipping containers designed to maintain an internal temperature of $2^{\circ}\text{--}8^{\circ}\text{C}$ for the duration of the study. Half of the vials (20 Ad26.ZEBOV and 20 MVA-BN-Filo) were subjected to simulated distribution testing, and half remained unstressed as controls. Control samples are non-distribution-tested samples exposed to freeze-thaw.

Figure). We determined the vibration sequence by using the International Safe Transit Association's web-based software application 4AB (https://ista.org/test_procedures.php#enhanced-simulation-section), selecting the truck profile to approximate truck transport in rural areas. During the 36-minute vibration test, vibration intensity increased and the vibration profile shape remained constant. Vials were oriented upside down to simulate a worst-case scenario.

After simulated distribution testing, we froze all 80 vials at -20°C and shipped them back to analytical laboratories, where they were stored at -85°C to -55°C before analysis. We applied assays for indicating critical quality attributes, including appearance, potency, quantity, aggregation, protein impurities, and presence of subvisible particles (Appendix Table 3). We conducted potency testing as described previously (10). We selected test methods and release specifications on the basis of regulatory guidance provided in the International Conference on Harmonisation Q6B and European Pharmacopoeia (12,13).

We compared assay results from the drug product vials with the control (unstressed) vials from the same batch of drug product and the release specifications,

noting any deviations that occurred during the study (Appendix). The attributes evaluated did not show substantial differences between stressed and control samples of Ad26.ZEBOV (Appendix Table 4). After the simulation, the appearance of the Ad26.ZEBOV drug product was clear, without coloration or visible particulate matter. Potency, quantity of Ad26.ZEBOV viral particles, and polydispersity were within release specifications. We observed no difference in the average hydrodynamic radius of stressed (54.2 nm) and control (55.2 nm) samples. Those values exceeded the current release specification (≤ 53 nm), which is attributable to the method used for this study having an ≈ 5 nm bias versus the release method. The percentage of main hexon identified on reverse phase ultra-high performance liquid chromatograms was numerically lower in both stressed (65.06%) and control (64.42%) samples versus the reference batch (75.1%). The percentage of free hexon was similar in stressed (4.3%) samples and the reference batch (4.0%).

We observed no substantial effect on attributes of the MVA-BN-Filo drug product between stressed and control samples after the simulation (Appendix Table 4). The appearance of material in both groups

was light yellow and milky, with no visible extraneous particles; product-related particles were present in the stressed vials. Potencies of stressed and control samples were within commercial release specifications. We confirmed the transgene expression of the Zaire Ebola virus (Mayinga), Sudan virus (Gulu), and Marburg virus (Musoke) glycoproteins and the Tai Forest virus nucleoprotein encoded by MVA-BN-Filo in stressed and control samples. Genomic vaccinia DNA contents were identical between the 2 groups. Average particle sizes measured by nanoparticle tracking analysis were numerically higher in stressed (195 nm) and control (191 nm) samples versus the reference batch (157 nm). Average virus particle sizes measured by fluorescence nanoparticle tracking analysis were numerically higher in the stressed samples (453 nm) versus both the control samples (399 nm) and the reference batch (394 nm). Total subvisible particle concentrations measured by microflow imaging were numerically higher in stressed (7.82×10^6 particles/mL) versus control (4.73×10^6 particles/mL) samples, whereas mean subvisible particle sizes were numerically lower in stressed (2.49 μm) versus control (3.26 μm) samples. We identified no substantial differences between stressed and control samples from the particle size distribution graphs of the 3 methods.

Conclusions

The stability of Ebola virus vaccine drug products is critical to ensure that quality remains unaffected in conditions likely encountered during distribution. We have shown that a liquid formulation for Ad26.ZEBOV/MVA-BN-Filo is suitable for mass vaccination in resource-limited regions at risk for outbreaks (10). We assessed the impact of shock and vibration, simulating rough-road transport conditions at 2°–8°C, on the quality of Ad26.ZEBOV/MVA-BN-Filo.

Product stability can be demonstrated through a quantitative measure of potency, which is linked to vaccine safety and efficacy (14). Potency can correlate with infectious titer and transgene expression and may be negatively affected by aggregate formation (14). Aggregates can affect immunogenicity and subsequently compromise vaccine efficacy (14). We have demonstrated that Ad26.ZEBOV and MVA-BN-Filo undergoing simulated distribution contained similarly sized aggregates and viral particles similar in number and potency to the control samples, suggesting that the immunogenicity of samples exposed to simulated rough-road transport would not differ from the control samples.

One limitation of this study is that the stress that may be encountered during in-country transport was simulated. However, the simulation used in this

study provides more realistic exposure to shock and vibration than can be generated by laboratory orbital shakers. Data on stability after agitation of alternative candidate Ebola virus vaccine regimens are limited in this regard (15).

In summary, this study shows that simulated, refrigerated (2°–8°C), rough-road truck transport, representative of the last mile of the supply chain, had no substantial effect on the quality of Ad26.ZEBOV/MVA-BN-Filo compared with the control condition. These findings confirm that refrigerated transport over rough terrain is possible and meets requirements for the challenging rural areas in the cold chain.

Medical writing support was provided by Sadie van Dyne and Courtney St. Amour, both of Lumanity Communications Inc., and was funded by Janssen Vaccines and Prevention B.V.

L.B., R.L., M.S., E.J., and T.H. are current employees of Janssen Vaccines and Prevention B.V. and may hold shares of Johnson & Johnson. L.G. is a current employee of Janssen Research and Development B.V. and may hold shares of Johnson & Johnson.

About the Author

Ms. Bus-Jacobs is Director of Chemistry, Manufacturing, and Control at Janssen Vaccines and Prevention B.V. in Leiden, the Netherlands. Her primary research interests include bioprocess technology (especially monoclonal antibodies and vaccines).

References

- Centers for Disease Control and Prevention. History of Ebola virus disease (EVD) outbreaks. 2022 [cited 2023 Jul 7]. <https://www.cdc.gov/vhf/ebola/history/chronology.html>
- European Medicines Agency. Zabdeno. 2020 Jul [cited 2023 Mar 3]. <https://www.ema.europa.eu/en/medicines/human/EPAR/zabdeno>
- European Medicines Agency. Mvabea. 2020 Nov [cited 2023 Mar 3]. <https://www.ema.europa.eu/en/medicines/human/EPAR/mvabea>
- World Health Organization. List of prequalified vaccines [cited 2023 May 16]. <https://extranet.who.int/pqweb/vaccines/list-prequalified-vaccines>
- Barry H, Mutua G, Kibuuka H, Anywaine Z, Sirima SB, Meda N, et al.; EBL2002 Study Group. Safety and immunogenicity of 2-dose heterologous Ad26.ZEBOV, MVA-BN-Filo Ebola vaccination in healthy and HIV-infected adults: a randomised, placebo-controlled phase II clinical trial in Africa. *PLoS Med.* 2021;18:e1003813. <https://doi.org/10.1371/journal.pmed.1003813>
- Anywaine Z, Barry H, Anzala O, Mutua G, Sirima SB, Eholie S, et al.; EBL2002 Study Group. Safety and immunogenicity of 2-dose heterologous Ad26.ZEBOV, MVA-BN-Filo Ebola vaccination in children and adolescents in Africa: a randomised, placebo-controlled, multicentre phase

- II clinical trial. *PLoS Med.* 2022;19:e1003865. <https://doi.org/10.1371/journal.pmed.1003865>
7. Ishola D, Manno D, Afolabi MO, Keshinro B, Bockstal V, Rogers B, et al.; EBL3001 Study Group. Safety and long-term immunogenicity of the two-dose heterologous Ad26.ZEBOV and MVA-BN-Filo Ebola vaccine regimen in adults in Sierra Leone: a combined open-label, non-randomised stage 1, and a randomised, double-blind, controlled stage 2 trial. *Lancet Infect Dis.* 2022;22:97–109. [https://doi.org/10.1016/S1473-3099\(21\)00125-0](https://doi.org/10.1016/S1473-3099(21)00125-0)
 8. Afolabi MO, Ishola D, Manno D, Keshinro B, Bockstal V, Rogers B, et al.; EBL3001 Study Group. Safety and immunogenicity of the two-dose heterologous Ad26.ZEBOV and MVA-BN-Filo Ebola vaccine regimen in children in Sierra Leone: a randomised, double-blind, controlled trial. *Lancet Infect Dis.* 2022;22:110–22. [https://doi.org/10.1016/S1473-3099\(21\)00128-6](https://doi.org/10.1016/S1473-3099(21)00128-6)
 9. Kieh M, Richert L, Beavogui AH, Grund B, Leigh B, D'Ortenzio E, et al.; PREVAC Study Team. Randomized trial of vaccines for Zaire Ebola virus disease. *N Engl J Med.* 2022;387:2411–24. <https://doi.org/10.1056/NEJMoa2200072>
 10. Capelle MAH, Babich L, van Deventer-Troost JPE, Salerno D, Krijgsman K, Dirmeier U, et al. Stability and suitability for storage and distribution of Ad26.ZEBOV/MVA-BN®-Filo heterologous prime-boost Ebola vaccine. *Eur J Pharm Biopharm.* 2018;129:215–21. <https://doi.org/10.1016/j.ejpb.2018.06.001>
 11. Hasija M, Li L, Rahman N, Ausar SF. Forced degradation studies: an essential tool for the formulation development of vaccines. *Vaccine: Development and Therapy.* 2013;3:11–33. <https://doi.org/10.2147/VDT.S41998>
 12. European Medicines Agency. ICH Q6B specifications: test procedures and acceptance criteria for biotechnological/biological products – scientific guideline [cited 2023 May 16]. <https://www.ema.europa.eu/en/ich-q6b-specifications-test-procedures-acceptance-criteria-biotechnological-biological-products>
 13. European Directorate for the Quality of Medicines & Healthcare. European pharmacopoeia [cited 2023 May 16]. <https://www.edqm.eu/en/d/99080>
 14. Sanyal G. Development of functionally relevant potency assays for monovalent and multivalent vaccines delivered by evolving technologies. *NPJ Vaccines.* 2022;7:50. <https://doi.org/10.1038/s41541-022-00470-4>
 15. Davis H, Dow T, Isopi L, Blue JT. Examination of the effect of agitation on the potency of the Ebola Zaire vaccine rVSVΔG–ZEBOV–GP. *Vaccine.* 2020;38:2643–5. <https://doi.org/10.1016/j.vaccine.2020.02.002>

Address for correspondence: Linda Bus-Jacobs, Janssen Vaccines and Prevention B.V., Archimedesweg 6, 2333 CN Leiden, the Netherlands; email: ljacobs1@its.jnj.com

etymologia revisited

Coronavirus

The first coronavirus, avian infectious bronchitis virus, was discovered in 1937 by Fred Beaudette and Charles Hudson. In 1967, June Almeida and David Tyrrell performed electron microscopy on specimens from cultures of viruses known to cause colds in humans and identified particles that resembled avian infectious bronchitis virus. Almeida coined the term “coronavirus,” from the Latin *corona* (“crown”), because the glycoprotein spikes of these viruses created an image similar to a solar corona. Strains that infect humans generally cause mild symptoms. However, more recently, animal coronaviruses have caused outbreaks of severe respiratory disease in humans, including severe acute respiratory syndrome (SARS), Middle East respiratory syndrome (MERS), and 2019 novel coronavirus disease (COVID-19).

References:

1. Almeida JD, Tyrrell DA. The morphology of three previously uncharacterized human respiratory viruses that grow in organ culture. *J Gen Virol.* 1967;1:175–8. <https://doi.org/10.1099/0022-1317-1-2-175>
2. Beaudette FR, Hudson CB. Cultivation of the virus of infectious bronchitis. *J Am Vet Med Assoc.* 1937;90:51–8.
3. Estola T. Coronaviruses, a new group of animal RNA viruses. *Avian Dis.* 1970;14:330–6. <https://doi.org/10.2307/1588476>
4. Groupe V. Demonstration of an interference phenomenon associated with infectious bronchitis virus of chickens. *J Bacteriol.* 1949;58:23–32. <https://doi.org/10.1128/JB.58.1.23-32.1949>

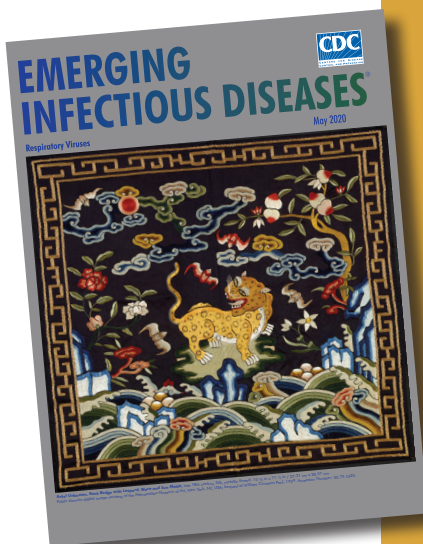

Originally published
in May 2020

https://wwwnc.cdc.gov/eid/article/26/5/et-2605_article

Effects of Shock and Vibration on Product Quality during Last-Mile Transportation of Ebola Vaccine under Refrigerated Conditions

Appendix

Supplemental Results

Protocol deviations

The first deviation involved the test laboratory inadvertently subjecting all 80 vials of Ad26.ZEBOV and MVA-BN-Filo to the distribution test sequence without reserving 20 vials of each drug product as controls. Twenty additional vials of each product from the same manufacturing lots were shipped to the analytical laboratory at -20°C , where they were thawed at $2^{\circ}\text{--}8^{\circ}\text{C}$ for 24 hours and returned to -20°C to mimic what would have happened at the simulation test laboratory. These vials were then sent for analysis. This deviation was considered to have no impact on the results of the study.

The second deviation occurred due to inadequate sample volume for reverse phase high performance liquid chromatography (RP-HPLC). A volume of ≥ 1.5 mL is required, but this amount was not available for the control samples. Due to the first deviation, there were 20 extra vials of the stressed sample from which adequate volume could be derived to perform free hexon quantification via RP-HPLC.

The third deviation involved invalid runs of the real-time polymerase chain reaction-based potency assay (QPA), which resulted in the need for retesting. However, there were insufficient backup samples available to rerun the assay. Given that it is known that 1 freeze-thaw cycle does not impact the product, it was determined that leftover samples could be used for retesting of the invalid runs.

Appendix Table 1. Materials used for packing and shipment of Ad26.ZEBOV and MVA-BN-Filo vaccine drug products. The target fill volume was 0.69 mL in a 2-mL vial

Material	Vial configuration
Ad26.ZEBOV	
Vial	Schott (type I glass)
Stopper	13 mm West 4432/50 (rubber)
Seal	13 mm West (aluminum flip off)
MVA-BN-Filo	
Vial	Thüringer Pharmaglas (type I glass)
Stopper	13 mm Datwyler FM457 (rubber)
Seal	13 mm West (aluminum flip off)

Appendix Table 2. Shock (drop) test sequence and parameters based on the International Safe Transit Association's software 4AB

Drop (orientation)*	Drop height, cm (31.8–68.0 kg)
1 (edge 3–4)	30.5
2 (edge 3–6)	30.5
3 (edge 4–6)	30.5
4 (corner 3–4–6)	30.5
5 (corner 2–3–5)	30.5
6 (edge 2–3)	30.5
7 (edge 1–2)	30.5
8 (face 3)	61.0
9 (face 3)	30.5

*Orientation of the packing materials is described in Appendix Figure.

Appendix Table 3. Analytical panel for analyzing Ad26.ZEBOV and MVA-BN-Filo drug products subjected to simulated distribution testing*

Attribute/assay	Test volume	Stressed vials (n)	Control vials (n)	Assay format (run × replicates)
Ad26.ZEBOV				
Appearance				
Degree of coloration				
Clarity	6000 µL	9	9	–
Visible particles				
Potency				
Infectious units by QPA	<500 µL	4†	4†	3 × 3
Quantity				
Virus particles by vp-qPCR	10 µL	4†	4†	3 × 3
Impurities/aggregates				
Average hydrodynamic aggregate radius by DLS	>250 µL	1	1	–
Polydispersity by DLS				
Protein profile/impurities				
Viral protein degradation products by RP-UPLC	<500 µL	1	1	–
Impurities				
Free hexon by RP-HPLC	≥1500 µL	1	1	–
MVA-BN-Filo				
Appearance				
Degree of coloration				
Clarity	1 vial	2†	2†	–
Visible particles				
Potency				
Infectious units by FACS				
Quantitative transgene expression (GP-Z-EBOV, GP-S-EBOV, NP-IC-EBOV, GP-MARV-MU)	500 µL	4†	4†	3 × 1
Quantity				
Quantification of genomic vaccinia DNA	1 vial	2†	2†	–
Aggregation				
NTA	1 vial	2†	2†	–
Virus particle aggregation				
Fluorescence NTA	1 vial	2†	2†	–
Subvisible particle aggregation				
MFI	1 vial	2†	2†	–

*DLS, dynamic light scatter; FACS, fluorescence-activated cell sorting; MFI, microflow imaging; NTA, nanoparticle tracking analysis; QPA, real-time polymerase chain reaction-based potency assay; RP-HPLC, reverse phase high-performance liquid chromatography; RP-UPLC, reverse phase ultra-performance liquid chromatography; VP-qPCR, virus particle real-time polymerase chain reaction.

†Includes 1 vial available for backup.

Appendix Table 4. Analytical test results for Ad26.ZEBOV and MVA-BN-Filo samples subjected to simulated distribution testing*

Attribute	Limit	Reference batch	Study results		Conclusion†
			Stressed	Control	
Ad26.ZEBOV					
Appearance					
Degree of coloration	<Reference solution B9, BY7, Y7, and GY7‡	<Reference solution B9, BY7, Y7, and GY7‡	<Reference solution B9, BY7, Y7, and GY7‡	<Reference solution B9, BY7, Y7, and GY7‡	Pass
Clarity	<Reference suspension III‡	<Reference suspension III‡	<Reference suspension III‡	<Reference suspension III‡	Pass
Visible particles	Essentially free of visible particulate matter	Essentially free of visible particulate matter	Essentially free of visible particulate matter	Essentially free of visible particulate matter	Pass
Potency					
Infectious units, log ₁₀ Inf.U/mL	≥9.30	9.55	9.48 (0.11)	9.49 (0.14)	Pass
Quantity					
Virus particles, vp × 10 ¹¹ /mL	0.5–2.0	0.8	0.81 (0.15)	0.74 (0.14)	Pass
Impurities/aggregates					
Aggregate radius, nm	≤53	53	54.2	55.2	No substantial difference
Polydispersity, %	≤25	7.7	6.4	6.9	No substantial difference
Protein profile/impurities					
Main hexon, %	–	75.1	65.06	64.42	No substantial difference
Unidentified peaks, %	–	4.2	3.06	2.99	No substantial difference
Impurities					
Free hexon, %	–	4	4.3	ND§	No substantial impact
MVA-BN-Filo					
Appearance					
Degree of coloration	Light yellow	Light yellow	Light yellow	Light yellow	Pass
Clarity	Milky	Milky	Milky (100–200 NTU)	Milky (100–200 NTU)	Pass
Visible particles	Homogenous suspension	Homogenous suspension	No visible extraneous particles but product-related particles present	No visible extraneous particles	Pass
Potency					
Infectious units, Inf.U × 10 ⁸ /mL	2.45–5.34	2.49	3.36 (0.26)	3.05 (0.47)	Pass
Transgene expression, TxgU/Inf.U	Expression confirmed				Pass
ZEBOV		0.58	0.59 (0.06)	0.63 (0.12)	
MARV		0.47	0.55 (0.04)	0.58 (0.04)	
NP		1.53	1.43 (0.07)	1.44 (0.06)	
SEBOV		0.54	0.48 (0.05)	0.49 (0.08)	
Coexpression, %		ND	45.5 (3.5)	45.5 (3.5)	Pass
Quantity					
Genomic vaccinia DNA, molecules × 10 ⁹ /mL	–	ND	1.70	1.70	No substantial difference
Aggregation					
Total particles × 10 ¹¹ /mL	–	ND	1.48	1.41	No substantial difference
Aggregate size, nm	–	157 (6)	195	191	No substantial difference
Virus particle aggregation					
Total particles × 10 ⁹ /mL	–	ND	5.66	5.52	No substantial difference
Aggregate size, nm	–	394 (42)	453	399	No substantial difference
Subvisible particle aggregation					

Attribute	Limit	Reference batch	Study results		
			Stressed	Control	Conclusion†
Total particles × 10 ⁶ /mL	–	ND	7.82	4.73	No substantial difference
Aggregate size, µm	–	ND	2.49	3.26	No substantial difference

*Data are presented as mean or mean (SD). B, brown; BY, brownish-yellow; GY, greenish-yellow; Inf.U, infectious units; ND, not determined; NTU, nephelometric turbidity units; TxgU, transgene units; Y, yellow.

†Conclusion is based on the result of a stressed sample analyzed by itself (no substantial t impact), in comparison with control (no substantial difference), or in comparison with commercial release specifications in cases of critical quality attributes (pass). A pass automatically signifies no difference between stressed and control samples.

‡Color reference solutions and reference suspensions are described in monograph 2.2.1 “Clarity and degree of opalescence of liquids” and 2.2.2 “Degree of coloration of liquids” of the European Pharmacopeia (<https://www.edqm.eu/en/d/99080>).

§A minimum volume of 1.5 mL was not available for control samples.

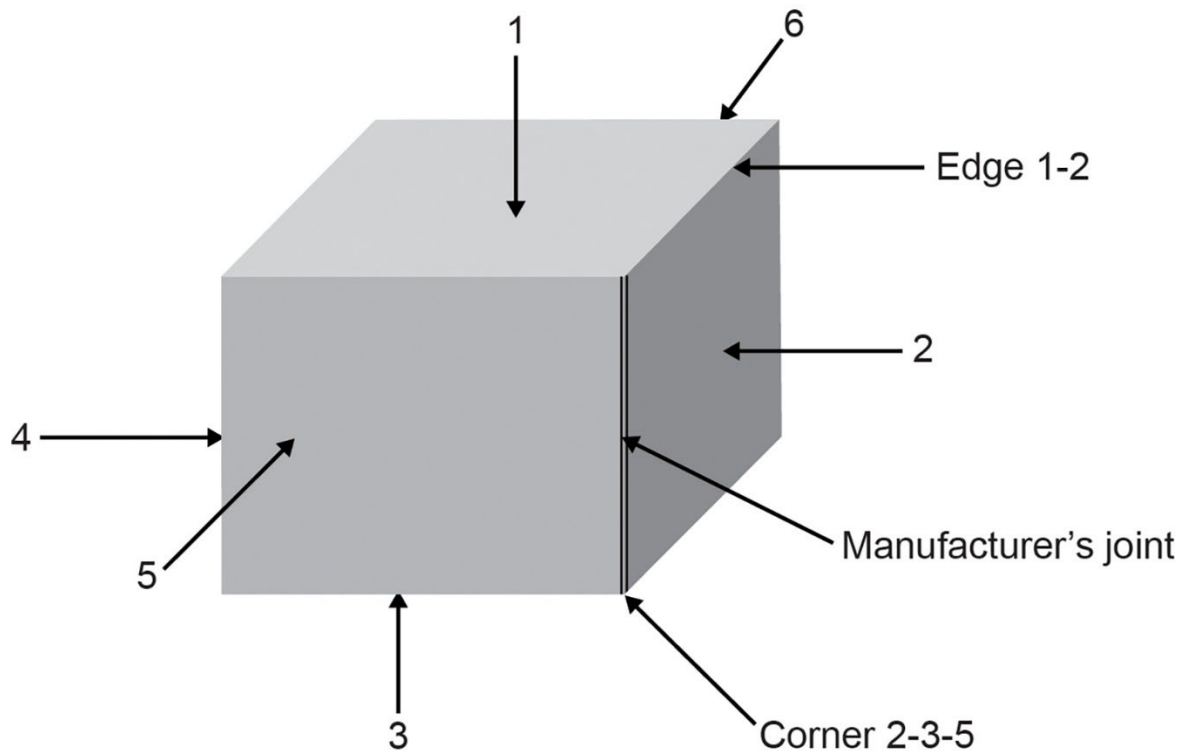

Appendix Figure. Orientation of packing materials during simulated distribution testing.